



ServoWorks™ CNC:

*Ultimate PC-Based,
Truly Open-Architecture
Soft CNC Solutions*

Powerful
PC-Based
Affordable
Scalable



Soft Servo
SYSTEMS, INC

Complete PC-based solutions for critical CNC requirements

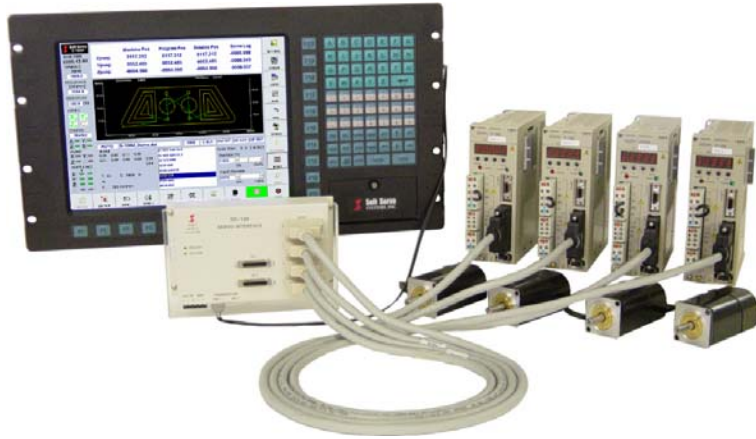

Soft Servo's ServoWorks™ CNC Product Line

Soft Servo Systems offers the following CNC products based on ServoWorks™ soft CNC technology:

- ServoWorks S-100M, S-120M and S-140M for mills and machining centers
- ServoWorks S-200M for 5-axis machining (under development)
- ServoWorks S-100T for lathes
- ServoWorks MC-Quad for 4-axis general CNC without a spindle control

LadderWorks PLC, for integrating soft PLC with CNC, is bundled with all our ServoWorks CNC products. ServoWorks MotionLite, a free utility for servo configuration, tuning and testing is included with ServoWorks MC-Quad, S-100M, S-120M, S-140M and S-200M. (ServoWorks S-100T has its own servo configuration, tuning and testing functions.)

Soft Servo Systems also offers extensive software development tools for developing customized ServoWorks solutions.

ServoWorks™: Unique Soft CNC Technology

All of Soft Servo Systems' CNC products are based on ServoWorks, our unique and proprietary PC-based motion control software technology. ServoWorks uses a single host CPU to perform all real-time servo and CNC tasks, including feedback loops, accelerations/decelerations, multi-axis coordination, G code processing, NC path generation and PLC, as well as providing the graphical user interface, program interpreting/loading, file management, data processing and network communications, all simultaneously.

ServoWorks CNC controllers run on top of the core ServoWorks software on Windows 2000, Windows XP or Windows XPe, with a real-time kernel.

Currently four servo communications platforms, based on different communications technologies, are available for off-the-shelf ServoWorks CNC products: VersioBus™ II, Panasonic Realtime Express™ (RTEX), MECHATROLINK™, and Mitsubishi SSCNET™.

Advantages of ServoWorks CNC Technology:

Powerful and High Performing

Unique soft CNC motion and soft CNC technology fully exploits the powerful and relatively inexpensive CPUs in personal computers to provide superior, incomparable CNC performance, allowing customers to increase productivity and reliability.

ServoWorks makes full use of the super-fast, super-precise (double-precision floating point) computation power of ordinary PCs, computation power which, until recently, was available only with a supercomputer. The ServoWorks CNC Engine provides customers with superior axis motion control performance. Our technologically advanced, multi-axis servo loops deliver ultra fast and accurate motion control. These servo loops are entirely closed in the CPU, and are optimized with velocity feedforward, backlash compensation, leadscrew pitch error compensation, linear scale feedback compensation, corner deceleration control, smoothing, interpolation and more.

Soft motion and soft PLC are integrated into a single motion/machine control application which gives customers incomparable motion and machine control.

ServoWorks CNC products support many modes of motion and are filled with functions and features, so that you will be able to produce high-quality parts quickly, easily and reliably.

Affordable and Innovative

PC-based technology enables users to take advantage of the ever-improving CPUs in personal computers to improve the performance of their systems.

ServoWorks products easily handle computation-heavy algorithms without additional expensive processors. All high-performance, multi-axis servo loops are entirely closed in software, eliminating the need for expensive plug-in motion control boards.

A unique and open architecture significantly reduces complex interface wiring and hardware requirements, and eliminates the need for high-priced proprietary encoder- or servo-specific interface modules, breakout boxes, complex interface wiring, and analog and encoder cables from the PC. Panasonic Realtime Express (RTEX), MECHATROLINK and Mitsubishi SSCNET interface systems are zero hardware systems. The VersioBus II interface system uses minimal hardware.

Setup, integration and maintenance are simple and fast, further reducing cost and time to market. Simple cabling and connections for all communications platforms minimize maintenance and total cost of ownership.

Customizable

It's easy to customize a ServoWorks CNC system to meet your exact motion control needs.

Because our soft motion technology is based on open architecture, customers can design and program motion applications with a comprehensive software development kit, making it easy to design and program customized ServoWorks CNC applications, taking full advantage of ServoWorks soft motion technology. Or you can purchase one of our many user-friendly CNC products.

ServoWorks CNC solutions are Windows-based (with a real-time extension), allowing customers to take advantage of sophisticated user interfaces, connectivity to enterprise networks, off-the-shelf PC technology, and integration with third-party Windows-based software, such as vision systems or statistical process control software.

Scalable and Flexible

ServoWorks products are designed to provide customers with exactly the number of axes to be controlled and the I/O capabilities required.

A handwheel can be included or excluded from your system. Soft Servo Systems offers an easy-to-operate handwheel, or customers can provide their own.

Mouse, keyboard and/or touch screen are all optional parts of a ServoWorks CNC system.

Our soft motion technology can be paired with one of six different interface platforms for servo drives and I/O communications, depending upon needs, to provide a solution that is right for you.

Powerful

Affordable

Customizable

Scalable



Features and Specifications of the ServoWorks CNC Family of Products

||| Servo Features

- Complete dual-axis synchronous control (except ServoWorks S-100M and S-100T)
- PID control
- Velocity feedforward
- Servo alarms
- Protective features
- Actual velocity measurement

||| Macro Features

- 99 local variables
- 400 numbered global variables (their values are lost when the control restarts)
- An unlimited number of symbolic global variables, with meaningful variable naming (such as "#position")
- 500 numbered permanent variables (their values remain when the control restarts)
- Up to 24,000 system variables (depending upon the number of axes, tool offsets, workpiece coordinate offsets, etc.)
- Extensive math operations:
 - Addition, subtraction, multiplication, division (+, -, *, /)
 - Sin, cos, tan, asin, acos, atan
 - Exponent, square root, absolute value
 - Rounding off, rounding down, rounding up
 - Natural logarithm, exponential function
 - OR, XOR, AND, NOT
 - Unlimited nesting of parenthesis
- Branching and repetition statements supported: GOTO, IF GOTO, IF THEN, IF ELSE ENDIF, WHILE
- Unlimited nesting of branching and repetition statements
- Macro calls using custom G, M, S and T codes

||| Part Program Storage and Editing

- Windows standard file management
- Storage of part programs is only limited by the size of your PC's internal hard disk
- Unlimited file size text editor
- Read from and write to your PC's floppy disk, zip disk, compact flash memory drive or PCMCIA card—whatever your PC includes for storage
- Save and load programs over a LAN through the Ethernet

||| Supported Operational Features

- High-speed block processing of up to 1000 blocks / sec
- Single block
- Optional block skip
- Dry run
- PLC axes (ServoWorks S-120M, S-140M and S-200M)
- Modes of motion include jogging, manual jogging with an optional handwheel, and rapid positioning
- Individual axis machine lock
- Individual axis and individual direction (forward and reverse) interlock (ServoWorks MC-Quad and ServoWorks S-100T)
- Handwheel feed interruption
- Manual intervention and return with manual absolute function
- Cycle start, cycle stop/feed hold
- Program stop (M00)
- Optional stop (M01)
- Program rewind (M30)
- Subprogram call from a main program (M98)
- End of subprogram and return to main program (M99)
- Emergency stop
- Overtravel limits (hardware limit switches and software stroke limits)
- Machine, workpiece, local and relative coordinates
- Standard STMB functions
- Three homing types

||| Display Features

- Simple, user-friendly colorful GUI — will seem familiar because it is Windows-based
- Full-screen single window with static display areas, permanently anchored toolbars and easy-to-use soft buttons for giving commands and accessing information
- Displays position data, plot, I/O status, servo status, NC status and motion monitoring
- Real-time program execution, position display and plotting
- Real-time I/O, servo, NC status and motion monitoring
- Data display is configurable on-the-fly, in terms of what position types are displayed

||| User-Friendly Operation

- All of our controllers were designed with both the machine operator and the machine integrator in mind, to be up and running quickly
- Soft Servo's products have been thoroughly tested by end users. Their feedback has been incorporated throughout the design process and continues to be an invaluable resource as we constantly improve our software.

Feed Features

- Maximum positioning speed: 300 M/min
- High speed cutting function (maximum cutting feedrate: 60 M/min)
- Dwell
- Manual feed with an optional pulse generator: x1, x10, x100, x1000 (except ServoWorks S-100T, which has x1, x10 and x100)
- Rapid traverse override (0 – 100%)
- Manual feedrate override (ServoWorks S-100T: 0 – 230%, all other ServoWorks CNC products: 0 – 254%)
- Per minute feed and per revolution feed (ServoWorks S-100T, S-100M, S-120M, S-140M and S-200M)

Axis Motion Control Performance

- Up to 16 axes of coordinated motion control — number of axes depends on the ServoWorks CNC product. Scalable in 4-axis increments. (VersioBus II interface system: 16-axis coordinated motion at 1 ms position feedback rate.)
- Linear interpolation
- Circular interpolation
- Helical interpolation (except ServoWorks S-100T)
- Exponential interpolation (except ServoWorks S-100T)
- Cylindrical interpolation (ServoWorks S-100T)
- Polar coordinate interpolation (ServoWorks S-100T only)
- Electronic gearing—one gearing ratio per axis
- Least input increment and accuracy: 1E–9 mm / 1E–10 in. (0.000000001 mm / 0.000000001 in.)
- Smoothing: acceleration and deceleration can be programmed for linear, bell-shaped and exponential filters
- Velocity feedforward to improve motion performance
- Backlash compensation
- Leadscrew pitch error compensation
- Linear scale feedback control
- Linear scale feedback compensation (ServoWorks MC-Quad)
- 16-bit analog output per axis (VersioBus II interface system)
- Opto-isolated overtravel limit switch inputs and home switch inputs for each axis (VersioBus II interface system)
- Corner deceleration control for sharper corners while maintaining high feedrates away from corners
- 1000 cycle three-dimensional dynamic look-ahead contour control (3D-DLACC) with pre-interpolation acceleration for high-speed, high-precision machining (except ServoWorks S-100T) [VersioBus II interface system: one second look-ahead for 1 ms position feedback rate]



Integrated Soft PLC

- Ladder logic
- 0.07 μ s/step (Pentium IV 2.4 GHz)
- Max 40,000 steps
- User-friendly ladder editor
- Real-time ladder monitor and time chart
- E-mail and telephone alert

Interface Features

- Simple and intuitive Windows-based HMI — easy to learn and easy to use
- Icon- and soft keys-based operation for manual data input: full-screen, single-window colorful graphical user interfaces with static display areas, permanently anchored toolbars and easy-to-use soft buttons, for giving commands and accessing information
- Auto Mode: real-time monitoring of G-code execution, with a part counter and a cycle timer
- 800 user configurable alarm messages programmable through PLC
- Password protection for parameter settings
- Easy connection of equipment to business-oriented applications running on the network
- Each ServoWorks CNC Windows HMI application can be fully customized by using the ServoWorks Development Kit (SDK)

Host PC Requirements

- CPU:
 - Minimum: Intel Pentium III 1 GHz or equivalent
 - Suggested and minimum for 3D-DLACC (three-dimensional dynamic look-ahead contour control): Intel Pentium IV 2 GHz or faster
- RAM: 256 MB (512 MB suggested)
- Hard disk space: 30 MB
- Operating system: Microsoft Windows 2000, Windows XP (Professional Ed.) or Windows XPe
- Ethernet connection: 10 MB/sec or 100 MB/sec
- ISA slot(s), PCI slot(s) and/or PC104 stacking connector, depending on the servo platform and hardware options
- Display:
 - 256-color graphic adapter
 - Color monitor capable of 800 x 600 pixel resolution (1024 x 768 recommended)
 - Recommended video chips: ATI or nVidia
 - Video chips that are incompatible with Soft Servo Systems' products: S3, SMI Lynx, Trident and VIA

NOTE: Depending upon your servo interface system, the location of the PCI slot, ISA slot or PC104 stacking connector of your PC adapter card(s), the location of the motherboard slot, and the hardware and software configuration, there is the potential that some PC functions might have to be disabled due to IRQ conflicts. These functions include, but are not limited to: USB, Ethernet, sound, modem, and some hardware components.

Soft Servo Systems recommends consulting with our sales staff prior to purchasing a PC for your Soft Servo Systems product.

S-100M™ /S-120M™ /S-140M™ : Complete CNC Solutions for Mills

Overview

ServoWorks™ S-100M™, S-120M™ and S-140M™ are innovative PC-based industrial CNC controllers for mills and machining centers. ServoWorks S-100M controls 4 axes: 3 coordinated CNC axes plus a spindle. ServoWorks S-120M controls 7 axes plus a spindle: 4 coordinated CNC axes and three axes that can be used for PLC axes or for synchronous control. ServoWorks S-140M controls 7 axes plus a spindle: 5 coordinated CNC axes and two axes that can be used for PLC axes or for synchronous control.

The S-100M, S-120M and S-140M can be used for three-, four- or five-axis mills and machining centers; laser, plasma and waterjet cutting machines; EDM machines; grinding and shearing machines, etc.

■ ■ ■ CNC Milling Functions

- 3 axes (S-100M), 4 axes (S-120M) or 5 axes (S-140M) simultaneous control, plus a C axis (spindle) for tapping and positioning capability
- Rigid tapping
- Split (dual) axis for gantry type control (S-120M and S-140M)
- Corner deceleration control for sharper corners while maintaining high feedrates away from corners
- 1000 cycle three-dimensional dynamic look-ahead contour control (3D-DLACC) with pre-interpolation acceleration for high-speed, high-precision milling [VersioBus II interface system: one second look-ahead for 1 ms position feedback rate]
- High-speed / high-precision machining: 60 m/min (2400 in/min)
- Complete drilling and boring canned cycles

■ ■ ■ Shape Cutting Capabilities and Features of ServoWorks S-140M

- 5 axes simultaneous control
- Complete dual-axis synchronous control
- 1000 cycle three-dimensional dynamic look-ahead contour control (3D-DLACC) with pre-interpolation acceleration for high-speed, high-precision cutting [VersioBus II interface system: one second look-ahead for 1 ms position feedback rate]
- Tool center point (TCP) control to simplify programming of complex workpieces
- Corner deceleration control for sharper corners while maintaining high feedrates away from corners
- Block search with calculation
- Normal direction control and bevel cutting
- Retrace function to retrace the programmed path backward up to 200 blocks

■ ■ ■ Product Features

- Macro functions (see page 4)
- Complete dual-axis synchronous control (S-120M and S-140M)
- Provides powerful, automatic execution of motion (part) programs, processing up to 1000 blocks per second
- Linear scale feedback control
- 6 workpiece coordinate systems
- Maximum positioning speed: 300 M/min
- Operates with or without a touch panel
- Can be used with a manual pulse generator (handwheel)
- Includes the ServoWorks MotionLite application for servo setup, configuration and tuning (see page 13)
- Can operate on the VersioBus™ II, Panasonic Realtime Express™, MECHATROLINK™ or Mitsubishi SSCNET™ communication platforms

■ ■ ■ Spindle Control Features

- Manual spindle control
- Spindle CW (M03) and spindle CCW (M04)
- Spindle stop (M05)
- Spindle speed override (50 – 120%)
- Actual spindle speed measurement and display
- Spindle orientation
- C axis control

■ ■ ■ Tool Compensation Features

- Tool offset compensation: geometry and wear offsets
- 256 pairs of tool offsets

■ ■ ■ Manual NC modes:

- (1) Jog Continuous Mode
- (2) Jog Incremental Mode
- (3) Rapid Mode
- (4) MDI Mode (manual data input)
- (5) Home Mode
- (6) HandWheel Mode (manual jog with a pulse generator)
- (7) Spindle Mode

■ ■ ■ PLC Features

- PLC axes for independent, individual positioning (S-120M and S-140M)
- Integrated soft motion and soft PLC (ideal for high-speed milling or high-speed cutting)
- Includes LadderWorks PLC (see page 13)

Supported G Codes

G00	Rapid positioning	G54-G59	Workpiece coordinate system 1–6 selection
G01	Linear interpolation	G54.1	Additional workpiece coordinate system selection
G02	Clockwise circular or helical interpolation	G61	Exact stop check mode
G03	Counterclockwise circular or helical interpolation	G64	Cutting mode
G02.3	Positive exponential interpolation	G64.1	Continuous cutting mode
G03.3	Negative exponential interpolation	G65	Simple macro call
G04	Dwell	G68	Coordinate system rotation
G05/G08	Dynamic look-ahead contour control on / off	G69	Coordinate system rotation cancel
G10	Program data input	G73	High speed peck drilling cycle
G17	XY plane selection	G74	Counter tapping cycle
G18	ZX plane selection	G76	Fine boring cycle
G19	YZ plane selection	G80	Canned cycle cancel
G20	Inch data input	G81	Drilling cycle, spot boring
G21	Metric data input	G82	Drilling cycle (dwell)
G28	Automatic return to the reference point	G83	Peck drilling cycle
G29	Automatic return from the reference point	G84	Tapping cycle
G30	Automatic return to the 2 nd , 3 rd and 4 th reference points	G85	Boring cycle
G31	Skip cutting	G86	Boring cycle (spindle stop)
G40	Tool radius compensation cancel	G87	Back boring cycle
G41	Tool radius compensation left	G89	Boring cycle (dwell)
G42	Tool radius compensation right	G90	Absolute command programming
G43	Positive tool length compensation	G91	Incremental command programming
G44	Negative tool length compensation	G92	Workpiece coordinate programming
G49	Tool length compensation cancel	G94	Feed per minute mode
G50	Scaling off	G95	Feed per revolution mode
G51	Scaling on	G98	Return to initial point in canned cycle
G50.1	Mirror image off	G99	Return to R point in canned cycle
G51.1	Mirror image on	G310	Linear interpolation feedrate include rotary axes
G52	Local coordinate system selection	G311	Linear interpolation feedrate exclude rotary axes
G53	Machine coordinate system selection		

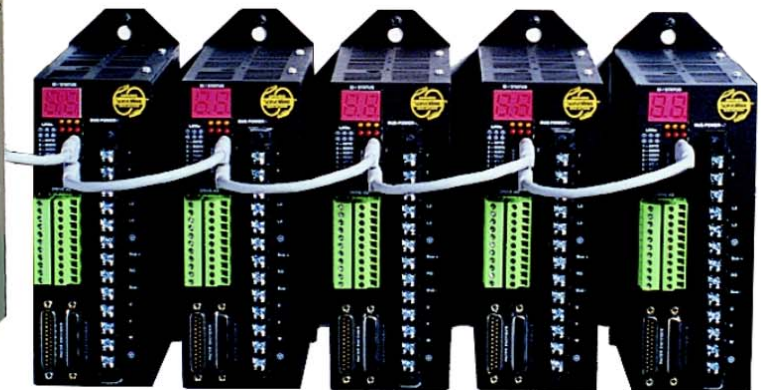

S-200M™ : Superior 5-Axis CNC Performance

Overview

ServoWorks™ S-200M™ (under development) is an innovative PC-based industrial CNC controller for powerful 5-axis machining of complex free-form shapes in a single setup. The S-200M controls 7 axes plus a spindle: 5 coordinated CNC axes, and two axes that can be used for PLC axes, synchronous control, or linear scale feedback.

CNC Milling Functions

- 5 axes simultaneous control, plus a C axis (spindle) for tapping and positioning capability
- Rigid tapping
- Complete dual-axis synchronous control
- Corner deceleration control for sharper corners while maintaining high feedrates away from corners
- 1000 cycle three-dimensional dynamic look-ahead contour control (3D-DLACC) with pre-interpolation acceleration for high-speed, high-precision machining [VersioBus II interface system: one second look-ahead for 1 ms position feedback rate]
- High-speed / high-precision machining: 60 m/min (2400 in/min)
- Complete drilling and boring canned cycles

PLC Features

- PLC axes for independent, individual positioning
- Integrated soft motion and soft PLC (ideal for high-speed milling)
- Includes LadderWorks PLC (see page 13)

Product Features

- Macro functions (see page 4)
- Provides powerful, automatic execution of motion (part programs, processing up to 1000 blocks per second)
- Linear scale feedback control
- 6 workpiece coordinate systems
- Maximum positioning speed: 300 M/min
- Operates with or without a touch panel
- Can be used with a manual pulse generator (handwheel)
- Includes the ServoWorks MotionLite application for servo setup, configuration and tuning (see page 13)
- Can operate on the VersioBus™ II, Panasonic Realtime Express™, MECHATROLINK™ or Mitsubishi SSCNET™ communication platforms

5-Axis Machining Features

- Tilted working plane commands to greatly simplify part programming, and automatically define the tool axis as perpendicular to the tilted plane
- Three-dimensional coordinate conversion to convert programming in a XY/ZX/YZ plane to any 3D plane
- Three-dimensional circular interpolation to program arcs and circles on a tilted working plane
- Three-dimensional handle feed to simplify tilted working plane machine setup
- Tool center point control to control the movement of the tool center point even if the rotary axes change
- Rotary table dynamic fixture offset to set up a workpiece on a fixture rotated on a rotary table

Spindle Control Features

- Manual spindle control
- Spindle CW (M03) and spindle CCW (M04)
- Spindle stop (M05)
- Spindle speed override (50 – 120%)
- Constant surface speed control (CSS)
- Actual spindle speed measurement and display
- Spindle orientation
- C axis control
- Spindle gear change — supports up to 4 gear stages

Tool Compensation with Advanced Features

- Tool offset compensation: geometry and wear offsets
- 256 pairs of tool offsets
- Tool length compensation in the tool axis direction
- Three-dimensional cutter radius compensation
- Thermal growth compensation along tool vector

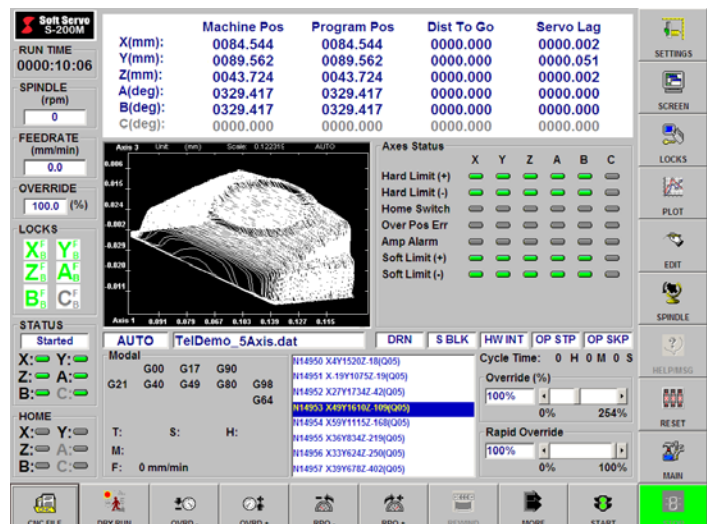

Supported G Codes

G00	Rapid positioning	G50.1	Mirror image off
G00.1	Rapid positioning with programmable acceleration / deceleration	G51.1	Mirror image on
G01	Linear interpolation	G52	Local coordinate system selection
G02	Clockwise circular or helical interpolation	G53	Machine coordinate system selection
G03	Counterclockwise circular or helical interpolation	G54-G59	Workpiece coordinate system 1–6 selection
G02.3	Positive exponential interpolation	G54.1	Additional workpiece coordinate system selection
G03.3	Negative exponential interpolation	G61	Exact stop check mode
G04	Dwell	G64	Cutting mode
G05	Dynamic look-ahead contour control on / off	G64.1	Continuous cutting mode
G08	Three-dimensional full circle specified by a center point	G65	Simple macro call
G10	Program data input	G66	Modal macro call
G11	Specifies the second point for a three-dimensional arc	G67	Modal macro call cancel
G11.1	Specifies the third point for a three-dimensional arc	G68	Coordinate system rotation/three-dimensional coordinate rotation (specified by vector and coordinate datum)
G12	Specifies the second point for a three-dimensional full circle	G68.1	Three-dimensional coordinate rotation on (specified by tool vector and another vector)
G12.1	Specifies the third point for a three-dimensional full circle	G69	Coordinate system rotation cancel/ three-dimensional coordinate rotation cancel
G12.2	Completes the three-dimensional full circle command	G73	High speed peck drilling cycle
G17	XY plane selection	G74	Counter tapping cycle
G18	ZX plane selection	G76	Fine boring cycle
G19	YZ plane selection	G80	Canned cycle cancel
G20	Inch data input	G81	Drilling cycle, spot boring
G21	Metric data input	G82	Drilling cycle (dwell)
G28	Automatic return to the reference point	G83	Peck drilling cycle
G29	Automatic return from the reference point	G84	Tapping cycle
G30	Automatic return to the 2 nd , 3 rd and 4 th reference points	G85	Boring cycle
G31	Skip cutting	G86	Boring cycle (spindle stop)
G40	Three dimensional cutter radius compensation cancel	G87	Back boring cycle
G41	Three dimensional cutter radius compensation on (left)	G89	Boring cycle (dwell)
G42	Three dimensional cutter radius compensation on (right)	G90	Absolute command programming
G43	Positive tool length compensation	G91	Incremental command programming
G44	Negative tool length compensation	G92	Workpiece coordinate programming
G49	Tool length compensation cancel	G94	Feed per minute mode
G50	Scaling off	G95	Feed per revolution mode
G51	Scaling on	G98	Return to initial point in canned cycle
		G99	Return to R point in canned cycle
		G130	Tool vector smooth interpolation off
		G131	Tool vector smooth interpolation on
		G310	Linear interpolation feedrate include rotary axes
		G311	Linear interpolation feedrate exclude rotary axes

ServoWorks™ S-100T™: An Advanced CNC Solution for Lathes

Overview

ServoWorks™ S-100T™ is a unique PC-based CNC controller for lathes, providing 2-axis motion control with a spindle, or 3-axis motion control including a C axis.

This industrial CNC solution supports all standard lathe operational functions and features, including indexing, plus live tools and all-axes simultaneous interpolation with a spindle (C axis). High performance CNC functionality and productivity allow customers to produce complex and precise parts quickly and easily.

Standard CNC Lathe Functions

- Drilling
- Chamfering
- Profiling
- Indexing
- Grooving
- Boring
- Cutting
- Multi-pass threading

C-Axis Control and Live Tool Features

- Full interpolation of X, Z and C axes
- Cylindrical interpolation
- Polar coordinate interpolation
- Face drilling
- Face tapping
- Face boring
- Side drilling
- Side tapping
- Side boring
- End face cutting cycle

Product Features

- Macro functions (see page 4)
- Provides powerful, automatic execution of motion (part programs, processing up to 1000 blocks per second)
- Workpiece coordinates (one external zero offset and 6 workpiece coordinate systems)
- Maximum positioning speed: 300 M/min
- Maximum cutting function: 60 M/min
- Operates with or without a touch panel
- Can be used with a manual pulse generator (handwheel)
- Can operate on the VersioBus™ II, Panasonic Realtime Express™, Mitsubishi SSCNET™ and MECHATROLINK™ communication platforms

Spindle Control Features

- Manual spindle control
- Spindle speed override (50 – 120%)
- Constant surface speed control (CSS)
- Actual spindle speed measurement and display
- Spindle gear change — supports up to 4 gear stages
- Spindle speed check

Tool Compensation Features

- Tool offset compensation: geometry and wear offsets
- 99 pairs of tool offsets
- Easy tool offset measurement: no calculations needed
- Tool nose radius compensations

Manual NC modes:

- (1) Jog Continuous Mode
- (2) Jog Incremental Mode
- (3) Rapid Mode
- (4) MDI Mode (manual data input)
- (5) Home Mode
- (6) HandWheel Mode (manual jog with a pulse generator)
- (7) Spindle Mode

Additional Interface Features

- On-line, interactive part program editing
- Graphical G-code input and editing facilitates part program creation

PLC Features

- Integrated soft motion and soft PLC
- Includes LadderWorks PLC (see page 13) [NOTE: LadderWorks Console, a Win32 application for ladder sequence program editing, is not included with ServoWorks S-100T at this time.]



Supported M Codes

M00	Program stop
M01	Optional stop
M02	Program end
M03	Spindle CW
M04	Spindle CCW
M05	Spindle stop
M08	Coolant on
M09	Coolant off
M10	Chuck unclamp, collet open
M11	Chuck clamp, collet close
M19	Indexing (spindle orientation)
M20	Indexing (spindle rotation mode)
M30	Program end and rewind
M50	Live tool #1 on
M51	Live tool #1 off
M52	Live tool #2 on
M53	Live tool #2 off
M54	Live tool #3 on
M55	Live tool #4 off
M98	Subprogram call from a main program
M98	Return to main program from a subprogram, or return to beginning of main program (if used in the main program)

Plus up to 82 customizable M codes through PLC

Supported G Codes

G00	Rapid positioning
G01	Linear interpolation
G02	Clockwise circular interpolation
G03	Counterclockwise circular interpolation
G04	Dwell
G09	Exact stop check
G10	Program data input
G20	Inch data input
G21	Metric data input
G22	Barrier check on
G23	Barrier check off
G25	Spindle speed fluctuation detection off
G26	Spindle speed fluctuation detection on
G28	Automatic return to the reference point
G29	Automatic return from the reference point
G30	Automatic zero return to 2 nd , 3 rd , 4 th reference points
G32	Thread cutting with a constant lead
G40	Tool nose radius compensation cancel
G41	Tool nose radius compensation left
G42	Tool nose radius compensation right

G50	Coordinate system preset and maximum spindle RPM
G52	Local coordinate preset
G53	Machine coordinate system selection
G54-G59	Workpiece coordinate system 1–6 selection
G61	Exact stop check mode
G64	Cutting mode
G65	Simple macro call
G70	Finishing cycle
G71	Stock removal in turning
G72	Stock removal in facing
G73	Pattern repeat cycle
G74	End face peck drilling/grooving
G75	Outer diameter/inner diameter grooving
G76	Multiple-pass threading cycle
G80	Hole machining canned cycle cancel
G83	Face drilling cycle
G84	Face tapping cycle
G85	Face boring cycle
G87	Side drilling cycle
G88	Side tapping cycle
G89	Side boring cycle
G90	Outer diameter/inner diameter cutting cycle
G92	Thread cutting cycle
G94	End face cutting cycle
G96	Constant surface speed control set
G97	Constant surface speed control cancel
G98	Per minute feed
G99	Per revolution feed
G107	Cylindrical interpolation
G112	Polar coordinate interpolation mode set
G113	Polar coordinate interpolation mode cancel
G164	Continuous cutting mode

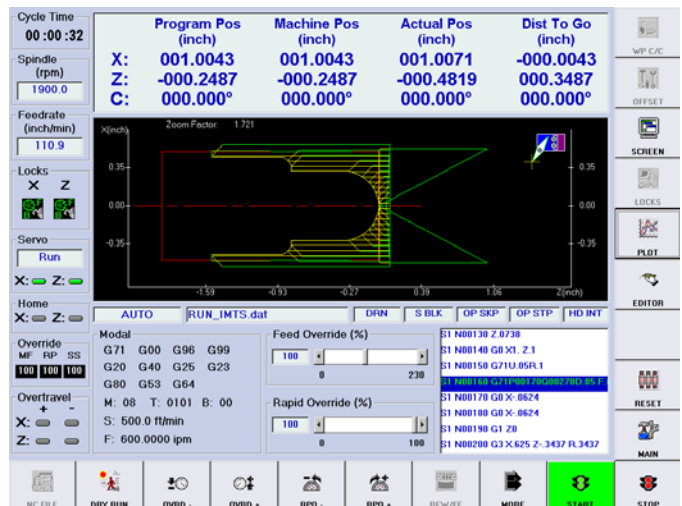

ServoWorks™ MC-Quad™ : Dynamic 4-Axis General CNC Solution

Overview

ServoWorks™ MC-Quad™ is an innovative PC-based motion control product for 4-axis general CNC applications. Designed as a controller for machines requiring CNC features but not requiring spindle functions, MC-Quad can be used for welding machines, milling machines and laser cutting machines, and can be customized for bending, punching, forming, measuring and EDM.

Product Features

- Macro functions (see page 4)
- 1000 cycle three-dimensional dynamic look-ahead contour control (3D-DLACC) with pre-interpolation acceleration for high-speed, high-precision machining [VersioBus II interface system: one second look-ahead for 1 ms position feedback rate]
- Complete dual-axis synchronous control (for gantry control)
- Corner deceleration control for sharper corners while maintaining high feedrates away from corners
- Linear scale feedback control
- Provides powerful, automatic execution of motion (part programs, processing up to 1000 blocks per second)
- 6 workpiece coordinate systems
- Maximum positioning speed: 300 M/min
- High-speed cutting function: 60 M/min
- Operates with or without a touch panel
- Can be used with a manual pulse generator (handwheel)
- Includes the ServoWorks MotionLite application for servo setup, configuration and tuning (see page 13)
- Can operate on the VersioBus™ II, Panasonic Realtime Express™, MECHATROLINK™ or Mitsubishi SSCNET™ communication platforms

PLC Features

- Integrated soft motion and soft PLC
- Includes LadderWorks PLC (see page 13)

Tool Compensation Features

- Tool offset compensation: geometry and wear offsets
- 256 pairs of tool offsets

Manual NC modes:

- (1) Jog Mode
- (2) Rapid Mode
- (3) Position Mode
- (4) Home Mode
- (5) MDI Mode
- (6) HandWheel Mode (manual jog with a pulse generator)



Supported G Codes

- G00 Rapid traverse
- G00.1 Rapid positioning with programmable acceleration / deceleration
- G01 Linear interpolation
- G02 CW circular or helical interpolation
- G03 CCW circular or helical interpolation
- G02.3 Positive exponential interpolation
- G03.3 Negative exponential interpolation
- G04 Dwell
- G05/G08 Dynamic look-ahead contour control on/off
- G10 Program data input
- G17 XY plane selection
- G18 ZX plane selection
- G19 YZ plane selection
- G20 Inch data input
- G21 Metric data input
- G28 Automatic return to the reference point
- G29 Automatic return from the reference point
- G30 Automatic return to the 2nd, 3rd and 4th reference points
- G31 Skip cutting
- G40 Tool radius compensation cancel
- G41 Tool radius compensation left
- G42 Tool radius compensation right
- G43 Positive tool length compensation
- G44 Negative tool length compensation
- G49 Tool length compensation cancel
- G50 Scaling off
- G51 Scaling on
- G50.1 Mirror image off
- G51.1 Mirror image on
- G52 Local coordinate system selection
- G53 Machine coordinate system selection
- G54-G59 Workpiece coordinate system 1-6 selection
- G61 Exact stop check mode
- G64 Cutting mode
- G64.1 Continuous cutting mode
- G65 Simple macro call
- G68 Coordinate system rotation
- G69 Coordinate system rotation cancel
- G90 Absolute command programming
- G91 Incremental command programming
- G92 Workpiece coordinate programming
- G310 Linear interpolation feedrate include rotary axes
- G311 Linear interpolation feedrate exclude rotary axes

MotionLite™ : Friendly & Free Servo Configuration, Tuning & Testing

Overview

ServoWorks™ MotionLite™, included with ServoWorks MC-Quad™, S-100M™, S-120M™ and S-140M™, is a free utility application for setup, configuration, servo tuning and testing of MC-Quad, S-100M, S-120M and S-140M systems. It can also be used for simple motion control to verify the system. MotionLite controls up to 16 axes, 4 axes at a time, with real-time monitoring of motion and I/O status.

Interface Features

- Incorporates simple and intuitive menu- and tab-driven HMI that is easy to learn and easy to use
- Manual NC modes:
 - (1) Jog Mode
 - (2) Position Mode (4-axis coordinated linear interpolation)
 - (3) HandWheel Mode (manual jog with a pulse generator)
 - (4) Block Buffer Mode (consecutive execution of blocks of code in a block buffer, for continuous motion)
- Test Mode: tuning of the ServoWorks system including velocity frequency/step response and position frequency/step response, in either sinusoidal or square wave

Comprehensive Setup, Configuration, Servo Tuning and Testing Features

- Includes ServoWorks CNC system setup and configuration functions, such as driver installation, FPGA initialization, setting of servo control and servo drive parameters, etc.
- Includes test operation modes for ServoWorks CNC system tuning such as velocity frequency/step response and position frequency/step response in either sinusoidal or square wave
- Interactive manual PID tuning
- Enhanced data sample and plot utilities (including continuous plot), for a lively visualization of system performance



LadderWorks™ PLC: A Complete Soft PLC Package

Overview

LadderWorks™ PLC is an independent PLC package included with all ServoWorks CNC products.

LadderWorks Console

- Win32 application for creating, importing, editing, monitoring, debugging and compiling PLC sequence programs
- Quickly insert functional commands by selecting functions from a pull-down menu, and entering parameters (if any) in pop-up text boxes; insert basic instructions by pointing and clicking on symbols within the easy-to-use GUI
- View Ladder Diagram (LD) or Instruction List (IL) format
- Search and print ladder diagrams
- Force component values while monitoring sequence programs

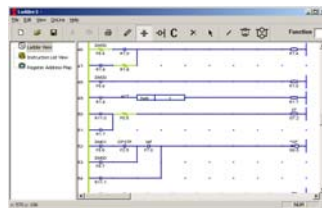

LadderWorks PLC Utilities for Debugging

- PLC Bit Pattern Utility — provides the current bit pattern for any signal address (F, G, X or Y data)
- PLC Time Chart Utility — shows the history of any specified bits in any signal addresses

LadderWorks PLC Engine

- Real-time soft PLC engine for industry-standard ladder logic control and execution of PLC sequence programs
- Provides control of axis modules — independent and individual positioning of PLC axes — useful for part feeders, tool changers, etc. (ServoWorks S-120M, ServoWorks S-140M, and ServoWorks S-200M)
- Seamlessly integrated with the ServoWorks CNC Engine into a single motion/machine control application providing uniform API functions
- Operates with Fanuc-compatible ladder logic
- Includes up to 416 opto-isolated I/O points for the VersioBus II interface system
- Provides deterministic, real-time performance
- Operates with a 5 msec standard scan time (8 msec for ServoWorks S-100T)
- Recognizes 38 function blocks and 12 basic commands, simplifying the programming of complex machine functions and allowing for quick and easy creation of sequence programs
- 100 bytes each for X and Y addresses
- 400 bytes each for F and G addresses

Soft Servo Offers a Wide Variety of Servo Communications Platforms

||| The Panasonic Realtime Express™ (RTEX) Ethernet-Based Interface System

- High-speed (100 Mbps), Ethernet-based digital synchronous servo communications technology developed by Matsushita Electric Industrial Co., Ltd.
- Low cost, high performance control of 32 axes with 0.5 ms – 1 ms cycle time
- High resolution and precise synchronization allowing interpolation
- All-digital, minimal-hardware control architecture
- Works with a single, low-cost commercial Ethernet LAN cable and Panasonic MINAS A4N servo drive systems
- IEC61000-4-4 compliant noise immunity
- Panasonic MINAS A4 series of servo drives and motors offer a slim design, motor output ranges from 50 W to 5 kW, 1,000 Hz speed-loop bandwidth and vibration suspension filters

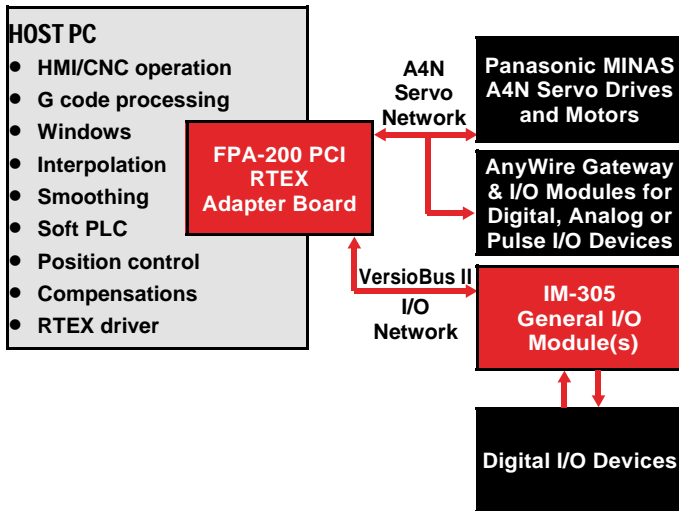

||| The VersioBus II Interface System

- Unique and proprietary 5 Mbps real-time fiber-optic digital servo communications protocol for interfacing with any conventional analog-interfaced servo drive using a single fiber-optic cable
- Runs on dual-channel VersioBus II servo and I/O communications
- Up to 16 axes of servo control, scalable in 4-axis increments
- Coordinated motion at a 1 ms position feedback rate
- Scalable general opto-isolated digital I/O up to 416 points
- Compatible with AC and DC motors and with incremental encoders — the ideal choice for servo communications for retrofitting existing machines or machine tools
- 16-bit analog output, opto-isolated forward and reverse overtravel limits, and home switch inputs for each axis
- Encoder and digital I/O connector for a handwheel on the VersioBus II adapter board, plus a 32-point on-board general I/O connector
- No noise to interfere with system communications

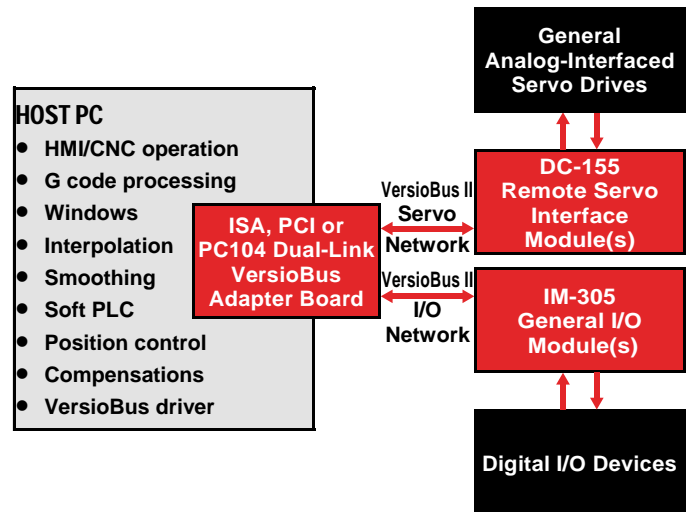

III The MECHATROLINK II Interface System

- Yaskawa's MECHATROLINK™ II (10 Mbps) for high-end digital servo and I/O network — reliable, versatile and economically efficient
- Market-leading, high-performance servo system
- All-digital, minimal-hardware control architecture
- Works with the Yaskawa family of digital servo systems (Sigma II, Sigma III or Sigma V series servo drives), inverters and I/O modules, as well as any MECHATROLINK-compatible devices from other companies
- Up to 30 stations can be integrated in one network, using a single, shielded twisted pair interface cable
- Low cost, high noise immunity transmission
- Data transfer rate: 10 Mbps
- 4 ms to 30 ms cycle times for up to 30 stations

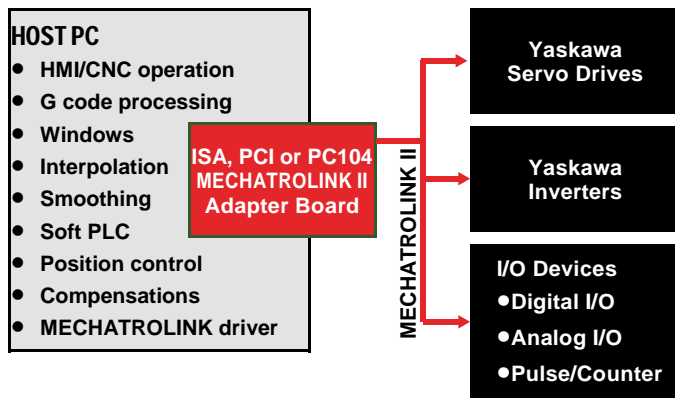

III Mitsubishi SSCNET Servo Communications

- Servo System Controller NETwork (SSCNET) bus system from Mitsubishi Electric Automation — a market-proven, high-speed servo network
- SSCNET™ (3.5 ms cycle time, range of 8 axes) and SSCNET™ II (0.88 ms cycle time, range of 6 axes) synchronous serial communications
- Works with the Mitsubishi family of MR-J2 Super AC servo drives
- Ideal for synchronous operation such as performance-demanding machine tool applications
- All-digital, minimal-hardware control architecture
- Plug 'N' Play — just plug in the cable to start communicating with servo drives
- Data transfer rate: 5.6 Mbps
- Noise problems are eliminated: all signals (including position data) are sent as serial data, not position pulses

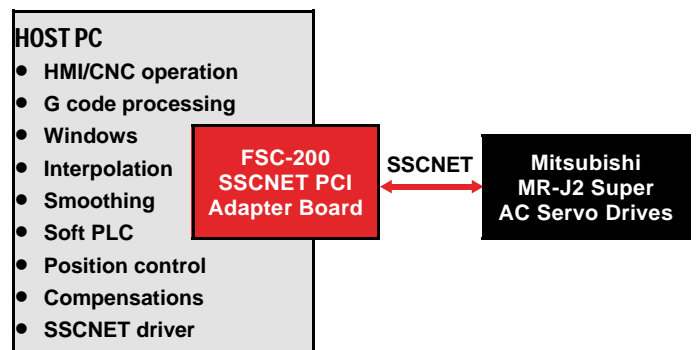

III The MECHATROLINK III Interface System

- Yaskawa's MECHATROLINK™ III Ethernet-based digital servo communications technology
- Integrates up to 62 stations in one network, using a single Ethernet interface cable
- Data transfer rate: 100 Mbps (ten times faster than MECHATROLINK II)
- Works with the Yaskawa's highly-acclaimed Sigma V series servo drives
- All-digital, minimal-hardware control architecture
- Supports hot plugging servo drives

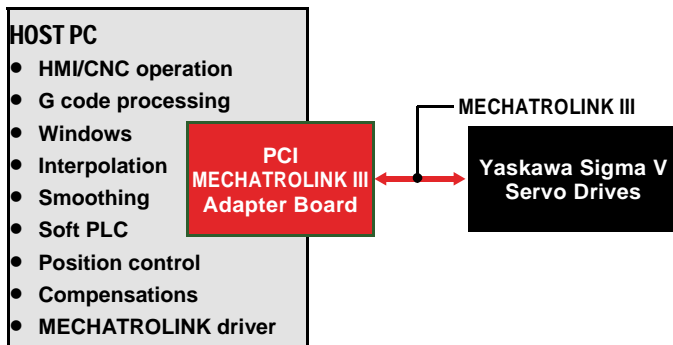

ServoWorks CNC Product Packages

Overview

The following ServoWorks™ CNC products are available for Windows:

- ServoWorks MC-Quad™
- ServoWorks S-100M™
- ServoWorks S-120M™
- ServoWorks S-140M™
- ServoWorks S-200M™
- ServoWorks S-100T™

All ServoWorks CNC products (in standard packages, without a PC) come with the following components:

- Windows HMI for each specific ServoWorks CNC product
- LadderWorks PLC, including the real-time LadderWorks PLC Engine and the LadderWorks Console for editing and monitoring PLC sequence programs
- ServoWorks MotionLite, a Windows application for setup and tuning of ServoWorks MC-Quad, S-100M, S-120M, S-140M and S-200M (not included with ServoWorks S-100T)
- Real-time ServoWorks CNC Engine specific to the product
- Real-time ServoWorks G-Code Parser specific to the product
- Real-time kernel for Windows
- Servo interface system: VersioBus II, MECHATROLINK, SSCNET or Panasonic Realtime Express (RTEX)

When ordering, the servo platform must be specified and the corresponding servo interface system will be provided as follows:

VersioBus II Interface System:

- One FP-85 (ISA) or FP-105 (PCI) VersioBus II adapter board
- One or two DC-155 remote interface module(s)*
- 4.5 m VersioBus II fiber-optic cable(s)*
- VersioBus II real-time device driver

Panasonic Realtime Express (RTEX) Interface System:

- One FPA-200 RTEX adapter board (PCI)
- RTEX real-time device driver

NOTE: Does not include RTEX cables (Ethernet cables).

MECHATROLINK II Interface System:

- One NT115 (PC104) or NT110 (PCI) MECHATROLINK II adapter board
- One PC104 to ISA adapter board (if NT115 is ordered)
- MECHATROLINK II real-time device driver

NOTE: Does not include MECHATROLINK II cables or terminators.

MECHATROLINK III Interface System:

- One NT112 (PCI) MECHATROLINK III adapter board
- MECHATROLINK III real-time device driver

NOTE: Does not include MECHATROLINK III cables or terminators.

SSCNET Interface System:

- One FSC-200 SSCNET adapter board (PCI)
- SSCNET real-time device driver

NOTE: Does not include SSCNET cables or terminators.

* ServoWorks MC-Quad, S-100T, and S-100M for the VersioBus II servo interface come with one set of a DC-155 and a VersioBus II fiber-optic cable. ServoWorks S-120M, S-140M and S-200M come with two sets of DC-155s and cables

||| ServoWorks Development Kit for Windows*

There are two packages for the ServoWorks Development Kit : a Standard Package and a Premium Package.

SDK Standard Package includes:

- SWAPI (ServoWorks APIs) for one of the following programming languages:
 - Visual Basic 6.0
 - C/C++
- Intensive sample source code

NOTE: The SDK Standard Packages does not include technical support or maintenance.

SDK Premium Package includes:

- All items in the SDK Standard Package (above)
- ServoWorks Simulator Package for a ServoWorks
- CNC product of user's choice
- Annual maintenance for the first year
- One-seat technical support (e-mail and phone) for the first year
- One-seat training for SDK programming (two days)

||| ServoWorks Simulator Packages

A simulator package is available and different for each ServoWorks CNC product. Each simulator package comes with a Windows HMI, a ServoWorks CNC Engine Simulator, a ServoWorks G-Code Parser Simulator, the LadderWorks PLC Engine and a real-time kernel for Windows.

* An SDK is available and different for each ServoWorks CNC product. A ServoWorks application to be developed by an SDK for a product would run on the ServoWorks CNC Engine of that product. For example, an SDK for MC-Quad would run on the MC-Quad CNC Engine.

||| Single Source CNC Packages with Panasonic MINAS A4N Drives or Yaskawa Drives

Total CNC packages with Panasonic MINAS A4-series servo drives and motors, or with Yaskawa Sigma II, Sigma III or Sigma V servo drives (with a choice of MECHATROLINK II, MECHATROLINK III or VersioBus II servo communications), are available.

Soft Servo Systems has a sales and technical partnership with Matsushita Electric Industrial Co., Ltd., allowing us to offer Panasonic MINAS A4-series servo drives and motors to our customers.

Soft Servo Systems also has a long standing business and technical partnership with Yaskawa Electric Company. This allowed us to be the first company in the United States to offer Sigma III servo drives with MECHATROLINK II servo communications, and one of the first third-party motion control providers of a system combining MECHATROLINK III and Sigma V technologies. These complete and economical CNC solutions for MECHATROLINK interface systems include world wide support.

We constantly work with Matsushita Electric Industrial Co. and Yaskawa Electric Company on providing the best motion control solutions for our customers.

||| ServoWorks Starter Package

ServoWorks Starter Package includes:

- Two-day technical training at a Soft Servo Systems facility for up to two people
- Annual software maintenance for the first year
- Technical support (e-mail and phone) for the first year

||| Application Source Code

Visual Basic source code for ServoWorks MC-Quad, S-100M, S-120M, S-140M, S-200M, S-100T or MotionLite

Our Software Development Tools Provide Ultimate Flexibility

Overview

Soft Servo Systems provides dynamic CNC solutions designed to meet specific industry needs. All of our products have been tested extensively by end users to ensure that we achieve the highest levels of quality and innovation. Despite all the preparation that goes into our development process, we know there will always be some customers who require something different in their CNC applications. With this in mind, we have made it easy for users to create or customize their own ServoWorks applications in C/C++ and Visual Basic 6.0 for Windows 2000/ XP/XPe.

Customers can program their own GUI or text-based ServoWorks application interface in one of two ways:

- (1) By using SWAPI, ServoWorks' extensive Motion Control APIs in the Win32 environment, provided in the form of Visual Basic 6.0, C/C++, Visual Studio .NET and Delphi. APIs are provided for complete and full access to all real-time processes and resources.
- (2) By modifying the source code of any ServoWorks GUI application. We offer source code in Visual Basic and C/C++ for customers to use as a basis for customizing their ServoWorks application. This may be the most efficient way to customize an application to meet exact specific needs.

Users can create a hybrid application of C/C++ and Visual Basic to take advantage of the faster execution time of C/C++ while using Visual Basic to quickly and easily create advanced, professional-looking GUIs.

Soft Servo Systems offers software development tools to facilitate development of customized applications capitalizing on ServoWorks technology: the ServoWorks Simulator and the ServoWorks Development Kit (SDK). We also offer software development services.

||| The ServoWorks Simulator

- Motion control and hardware are simulated in the ServoWorks Simulator without requiring an adapter board for the host PC. Users can “play” with the software without having hardware or motors connected to a PC. For instance, users can “jog” an axis that doesn't exist, and see that “movement” reflected in the display of position data, the plot display, etc.
- The ServoWorks Simulator has two different purposes:
 - (1) **Software Development.** With simulated motion control, developers can quickly test applications under development, without the possibility of damaging hardware or machines.
 - (2) **Training.** New or potential operators can try out ServoWorks applications without worrying about damaging real (and costly) hardware. The ServoWorks Simulator is the perfect vehicle for training operators to use ServoWorks CNC products.
 - (3) **Part Program Verification/Testing.** Programmers can test part programs and view plots created by those plot programs.

||| ServoWorks Development Kit (SDK)

- The ServoWorks Development Kit is a package for software developers who want to create their own, customized motion control applications based on ServoWorks technology and on SWAPI (ServoWorks motion control APIs in the Win32 environment), which forms the core of SWSDK.
- SDK jump-starts users in developing their own customized ServoWorks applications, while taking full advantage of ServoWorks technology quickly and easily.
- SDK comes in two packages: Standard and Premium.

SDK Standard Package includes:

- One of the following forms of SWAPI:
 - SWAPI Visual Basic 6.0 Module Package—reusable code modules to include in Visual Basic project to make the ServoWorks API functions part of the application
 - SWAPI C/C++ Interface Package, including header files and a library file to include in C or C++ projects
- Intensive sample source code for simple C/C++ and Visual Basic applications — models how to use SWAPI functions
- An extensive API reference manual — a complete, organized resource clearly explaining the ServoWorks APIs, making them easy to use in building an application
- An intensive and user-friendly programming manual including an explanation of ServoWorks technology, code examples, and more

NOTE: Does not include technical support or maintenance.

SDK Premium Package includes:

- All items in the SDK Standard Package
- A ServoWorks Simulator Package for one of Soft Servo Systems' CNC products
- Annual maintenance for the first year
- One-seat technical support (e-mail and phone) for the first year
- One-seat training for SDK programming (two days)

Soft Servo Systems, Inc. Corporate Profile

Soft Servo Systems, the leading provider of PC-based motion control products, was founded in February 1998 by MIT professionals with funding from private investors.

Soft Servo Systems was among the first to develop a truly PC-based servo controller in which a single, powerful host computer, combined with FPGA technology, performs all real-time servo control operations. Our products integrate and leverage this servo control with the most advanced information and communication technologies. In addition to handling feedback loops, multi-axis coordination and NC path generation, the computer also provides the graphical user interface, data processing, plant monitoring, network communication, file management, and more.

Soft Servo's soft CNC products are based on our unique and proprietary ServoWorks technology that fully exploits the ever-improving CPUs in personal computers to give customers superior CNC performance. Soft CNC technology eliminates the need for a motion control coprocessor card. The multi-axis servo loops are entirely closed in the CPU and provide extremely fast and accurate motion control. The end result is a highly flexible, low cost control system, with exceptional features that traditional PC-based controllers (still requiring motion control boards) cannot provide.

Soft Servo's soft CNC technology enables customers to build their own products without depending on the proprietary information and black box technology provided by NC vendors. We believe that machine tool builders know the real needs in their fields much better than NC vendors. Our soft motion technology allows users to implement their unique product concepts and use their valuable know-how to build the best possible CNC products. Let Soft Servo's PC-based motion control help you to achieve the ultimate flexibility and intelligence in building your CNC system.

Soft Servo Systems' Mission:

- To provide high-performing yet affordable and reliable CNC solutions to industrial machine builders and other users by exploiting the high-speed, ever-improving CPUs of personal computers.
- To revolutionize motion control for the manufacturing industry by leveraging and integrating the latest developments in information and software technologies.

Consult the ServoWorks CNC Product Parts List or your Soft Servo Systems sales representative regarding standard and optional features for these products.



Revised January 27, 2009

39 Whitcomb Street
Waltham, MA 02453
USA
Tel: 1.781.891.9555
Fax: 1.781.891.3853
www.softservo.com

Send inquiries to:
info_usa@softservo.com

© Copyright 2009 Soft Servo Systems, Inc.

LadderWorks, MC-Quad, Motion Engine, MotionLite, PLC Engine, ServoWorks, ServoWorksCNC, ServoWorksPLC, SoftServo, SMP and VersioBus are trademarks of Soft Servo Systems, Inc. RTX is a registered trademark of Ardence, Inc. Realtime Express and Panasonic are registered trademarks of Matsushita Electric Industrial Co., Ltd. MECHATROLINK is a registered trademark of YASKAWA ELECTRIC CORPORATION. SSCNET is a registered trademark of Mitsubishi Electric Corporation. Microsoft, Windows 2000, Windows XP and Windows XPe are registered trademarks of Microsoft Corporation. Pentium is a registered trademark of Intel Corporation. All other trademarks are properties of their respective owners.